

Box Liner

» Type: SZC 18 eL20'

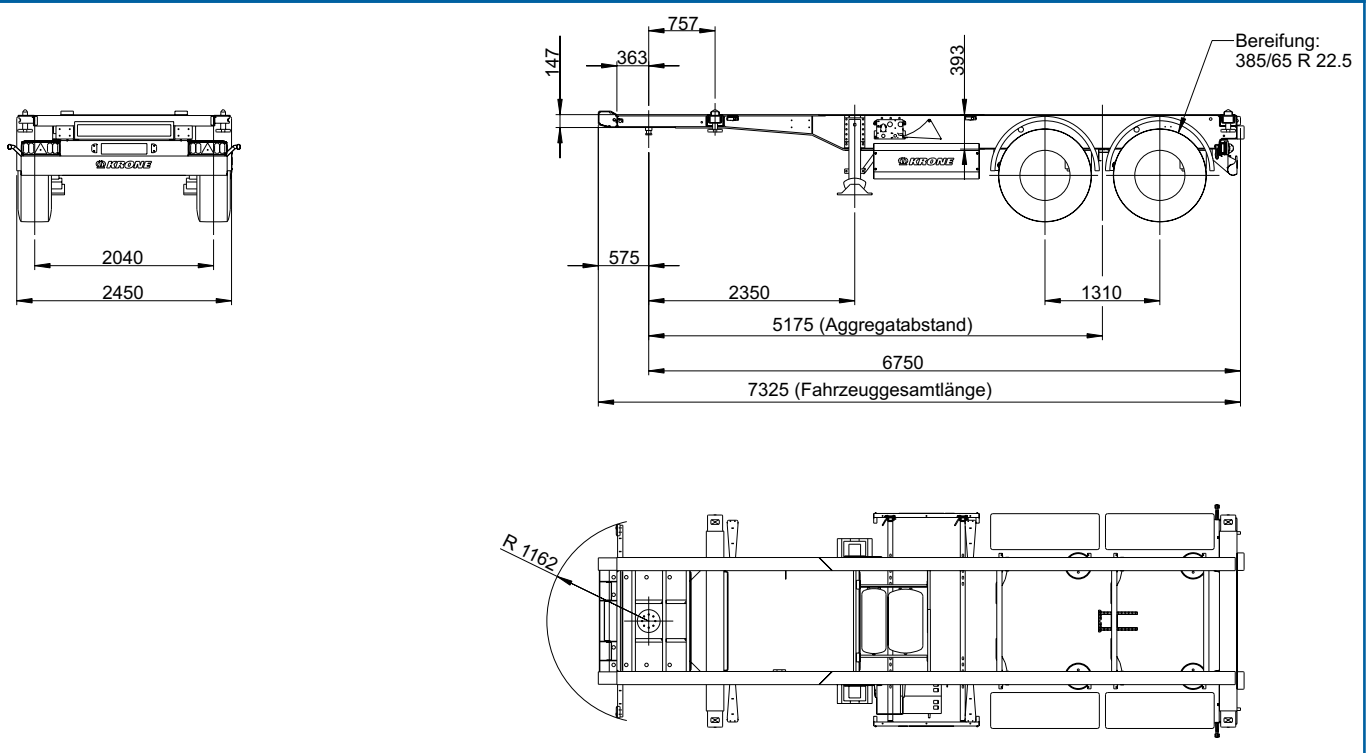

Chassis with corresponding locks for container transport: 1 x 20'



Technical data	
Type:	SZC 18 eL20'
King Pin load:	12,000 kg
Axle load (technically possible):	18,000 kg
Perm. total weight (technically possible):	30,000 kg
Tare weight:	approx. 2,800 kg
Payload (technically possible):	approx. 27,200 kg
Axle spread:	1,310 mm
5th wheel height:	1,150 mm
Neck height (incl. coupling plate):	147 mm
Distance kingpin - rear end:	6,750 mm

(Dimensions and weights for standard units)

Load distribution:						
Loading options	Total weight of containers (kg)	Coupling load		Axle load		Total weight (kg)
		(kg)	(%)	(kg)	(%)	
20'	22,000	7,350	29	17,800	71	25,150

Technical description
Chassis made of I beams welded to crossmembers; bolted 2" kingpin, 1 position: mounted on 575 mm, neck height: 147 mm (incl. coupling plate); rear underrun protection and side guards acc. to EC regulation
1 x 20' Container lockings rear position
2 mechanically operated landing legs, 2 x 12 tones capacity, half round compensating feet
Low-maintenance axles with air suspension and disc brakes (430 mm); raise/lower valve incl. auto reset valve; Rims centre nave
Tyres: 4 x 385/65 R 22.5, brand: Krone choice
Wheel covering according to EC-regulations; Spray suppression according to EC-guidelines
spare wheel carrier as an option
EC braking system including vehicle stabilising system; low-maintenance automatic; spring-loaded hand brake; 2S/2M EBS system, 2 sensors on each axle with RSS, diagnostics on ISO 7638 socket (EBS)
24 volts lighting system with 2 x 7-pin socket DIN ISO 1185/3731; front and rear marker lights; with two multi-function rear lights acc. to EC incl. rear fog light and reversing lights; 2 large contouring lights with rubber arm; side marker lights in LED
Steel parts shot blasted, with KTL primer and high-quality surface coating (standard painting single-colour); axles incl. wheel hubs painted black; underrun protection and light panel powder coated white for safety reasons; wheels silver with high-quality paint finish; accessories black or galvanized; reflective outline marking according to ECE-R48

