

3 axle refrigerated trailer in Multitemp style with ATP/FRC certificate – side view and rear view

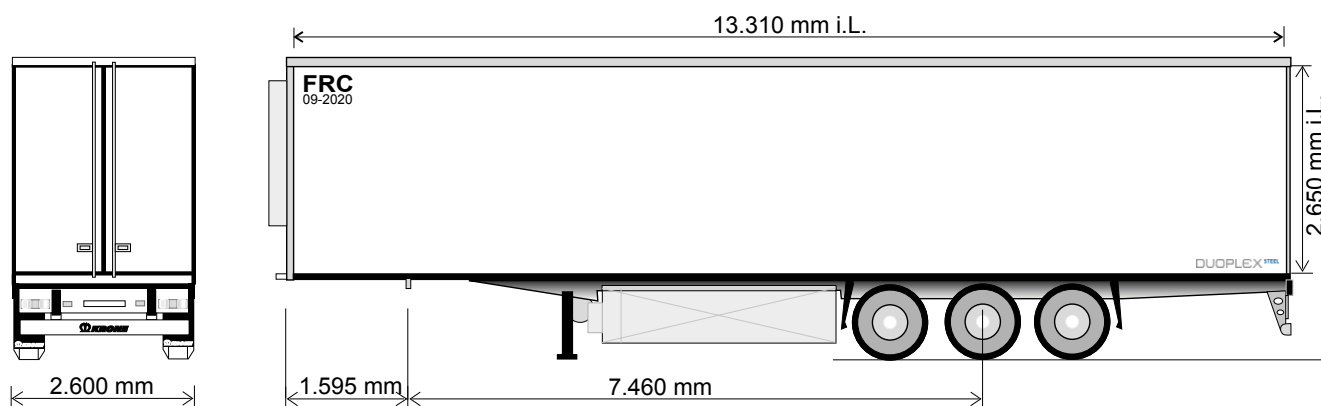

Technical data

Type:	SDR 27 eL4-MT
King Pin load:	12,000 kg
Axle load (technically possible):	27,000 kg
Perm. total weight (technically possible):	39,000 kg
Tare weight (without cooling unit):	ca. 8,000 kg
Coupling height unloaded:	1,150 mm
Axle spread:	1,310 / 1,310 mm
Internal length:	13,310 mm
Internal width:	2,465 mm
Internal height:	2,650 mm

(Dimensions and weights for standard units)

Technical description:

Continuous chassis construction with double T/Z-profile longitudinal beams and cross members; rear traverse with diagonal reinforcements, neck height: 10 mm	Self-supporting box in thermal bridge free panel construction, panels on both sides with steel outer skin (painted outside, inside PVC coated); side walls inside with GRP covering (instead of steel); foam 100 % CFC-free
2 mechanically operated landing legs, 2 x 12 tonnes capacity, half round with base plate	Roof as sandwich panel; LED-flush ceiling lamps, door contact switch for ceiling lamps
Low-maintenance axles with air suspension and disc brakes (430 mm); raise/lower valve (1 valve) incl. auto reset	Front wall as sandwich panel; floor connection with chafe-resistant kick strip; 4 vertical alloy distance profiles for optimal air flow; front wall with bolted protection wall
Tyres: 6 x 385/65 R 22.5, brand: Krone choice	Side wall as sandwich panel; steel reinforcements for meat hang rails integrated into the walls, floor connection with chafe-resistant kick strip
Wheel covering according to EC-regulations; Spray suppression according to EC-guidelines	Container type double rear doors; alloy steel die cast hinges on each door, multiple lipped door sealing system with outside dust protection, one pair of stainless steel door lock rods; 4 door lockings with 1 hand operation; alloy chafe-resistant kick strip inside the doors
spare wheel carrier as an option	Air duct; ATP-certificate; load securing certificate according to EN 12642 Code XL; cooling unit by request for extra charge; Hinged and movable bulkhead with overhead locking device
Brake system according to ECE R 13, including vehicle stabilising system; spring parking brake; 2S/2M EBS system, 2 sensors on one axle with RSS, diagnostics by ISO 7638 socket (EBS)	Steel parts shot blasted, with KTL System and high-quality surface coating; axles incl. wheel hubs coated black; underrun protection and light supports white for safety reasons, powder-coated; wheels silver with high-quality paint finish; accessories black or galvanized; laminate coating coloured in RAL 9010 white; reflective outline marking according to ECE-R48
Lights according to UN ECE reg. no. 48; 24 volts lighting system with 2 x 7-pin socket DIN ISO 1185/3731; front and rear marker lights; two multi-function rear lights incl. rear fog light and reversing lights; contouring lights, number plate lights and side marker lights in LED	
Plastic fuel tank, approx. 240 litres (when equipped with cooling unit); closed pallet box for 36 Euro-pallets, 1 PVC tool box	
Low-noise alloy floor, PIEK qualified; floor load capacity tested acc. to CSC/EN 283; reinforced at rear	