

Profi Liner Ultra with EasyTarp - Side curtain and pneumatic quick release fastener and FuelSaver Kit

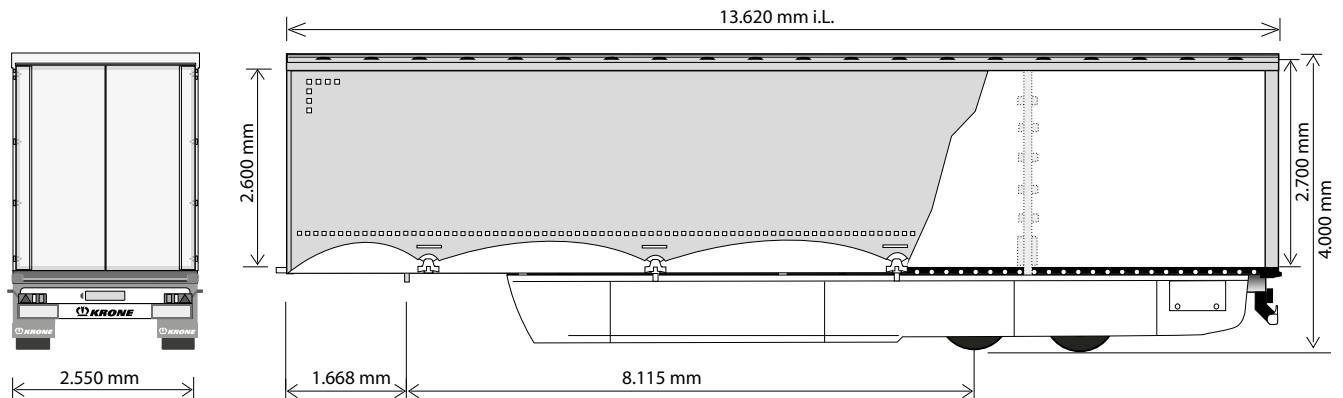

Technical data:

Type:	SZP 20 eLUB-PZ
King pin load:	12,000 kg
Axle load (technically possible):	20,000 kg
Allowable gross weight (technically possible):	32,000 kg
Tare weight, approx.:	6,650 kg
Payload (technically possible):	25,350 kg
Axle spread:	1,810 mm
Neck height:	125 mm
5th wheel height:	1,050 - 1,170 mm
Side access length:	13,620 mm
Side access height:	2,575 - 2,800 mm
Side access width:	2,480 mm
Turning radius:	2,040 mm

(Dimensions and weights for standard units)

Multi Lock side rave as standard:

Award winning Multi Lock side rave including load securing positions every 100 mm. Load securing even diagonally to the driving direction with more than 3000 strapping positions. Cost-effective and with best benefit.



No matter which loads should be transported, with the new Multi Lock / Multi Blocks system the loads are perfectly secured.

Technical description:

Fuel Saver - side covering (long version); Multi Lock side rave including load securing positions every 100 mm	Alloy cant rail, continuous, for support of sliding curtain and posts, sliding roof, height 125 mm, Roof also movable to the front and rear; Diagonal roof spanning; 4 sets of wooden planks
2 mechanically operated landing legs, 2 x 12 tonnes capacity, half round compensating feet	Alloy Front wall with solid corner posts; lateral restricted through loading; Front wall reinforced with plywood inner skin; retainer for curtain cord
Low-maintenance axles with air suspension and disc brakes (430 mm); raise/lower valve incl. auto reset valve; Rims centre nave	Alloy container rear doors including bolted steel frame, integrated double door looks and concealed door hinges; roof header hinged and movable
Tyres: 4 x 385/65 R 22.5, brand: Michelin XM216	3 pairs of side posts, symmetrical, plank pockets for posts
without wheel covering, with Fuel Saver - side covering	Delta shaped rubber profiles at rear; delta steel buffers at rear; load security certificate according EN 12642 Code XL
spare wheel carrier as an option	Symmetrical EasyTarp - Side curtain with pneumatic quick release fastener; Roof curtain white
EC braking system including vehicle stabilising system; Aluminium air tank; low-maintenance automatic; spring-loaded hand brake; 2S/2M EBS system, 2 sensors on each axle with RSS, diagnostics on ISO 7638 socket (EBS)	Steel parts shot blasted, with KL primer and high-quality surface coating (standard painting single-colour); axles incl. wheel hubs painted black; underrun protection and light panel powder coated white for safety reasons; wheels silver with high-quality paint finish; reflective outline marking according to ECE-R48
24 volts lighting system with 2 x 7-pin socket DIN ISO 1185/3731; front and rear marker lights; with two multi-function rear lights acc. to EC incl. rear fog light and reversing lights; 2 contouring lights with rubber arm in LED; side marker lights in LED	
30 / 21 mm thick, phenolic coated plywood floor, cut surfaces fully waterproofed and sealed. Strength acc.to DIN 283; for floor loadings up to 5,460 kg stacker-truck axle load	